

BELT CONVEYORS

NP CONVEYOR

This conveyor belt is designed to be placed under the processing machinery for collecting and conveying parts directly after ejection from the processing machine.



mod.	L	U	I
NP1	1500	250	305
NP2	1500	350	405
NP3	1500	450	505

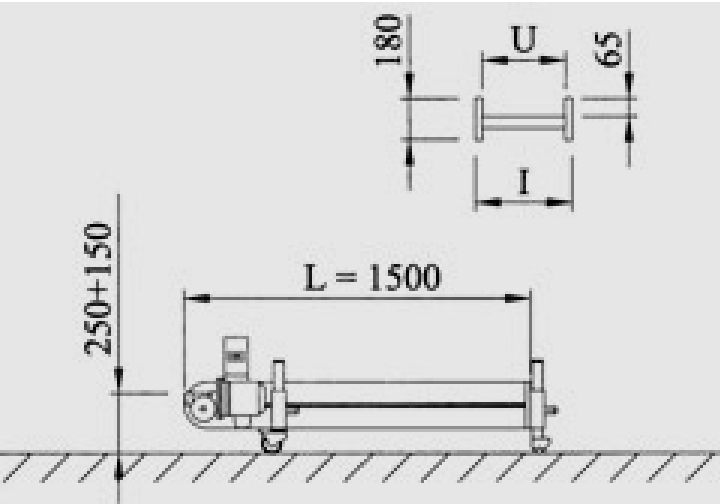

www.techspanonline.com

Australia:
 P O Box 1012, Mascot, NSW 1460, Sydney
 Ph: 1-800 148 791 Fx: 1-800 148 799
 sales@techspanonline.com www.techspanonline.com

New Zealand:
 P O Box 15262, New Lynn, Auckland
 Ph: ++64 (09) 8276567 Fx: ++64 (09) 827 6596
 sales@techspanonline.com www.techspanonline.com